

# ZETHA

Autonomous Mobile Robot



Maximum Payload : 1 ton



Maximum Speed: 1m/s



360 Lased-based natural features navigation

# AMR BASE

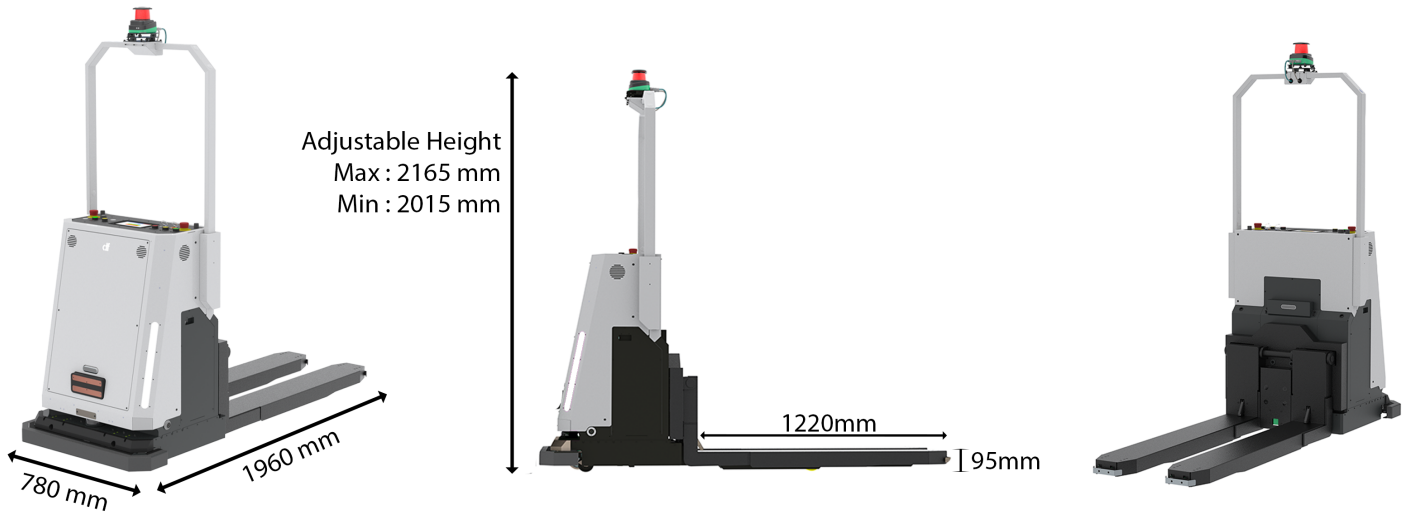

# CHARGING METHOD

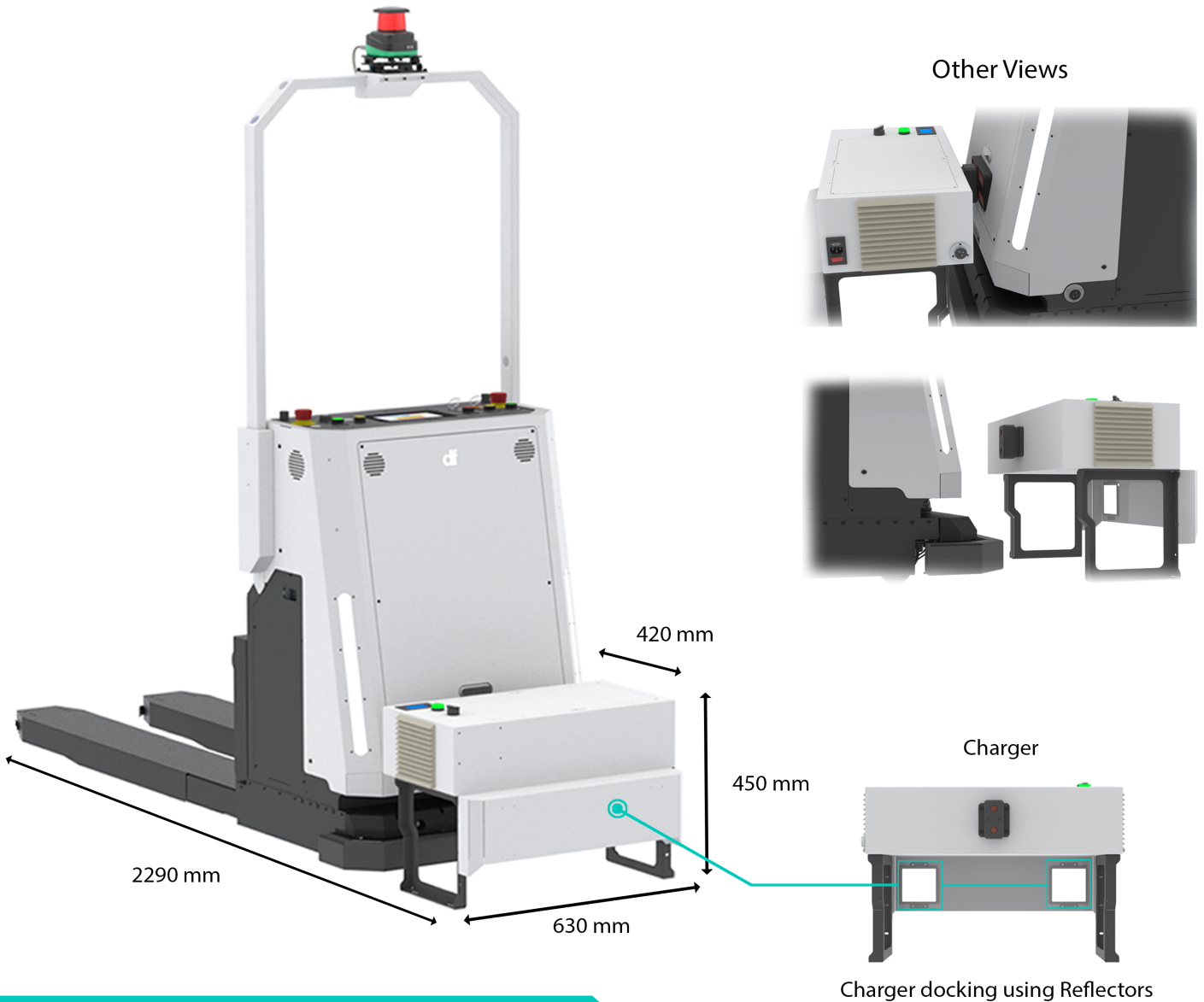



# Sensing Features

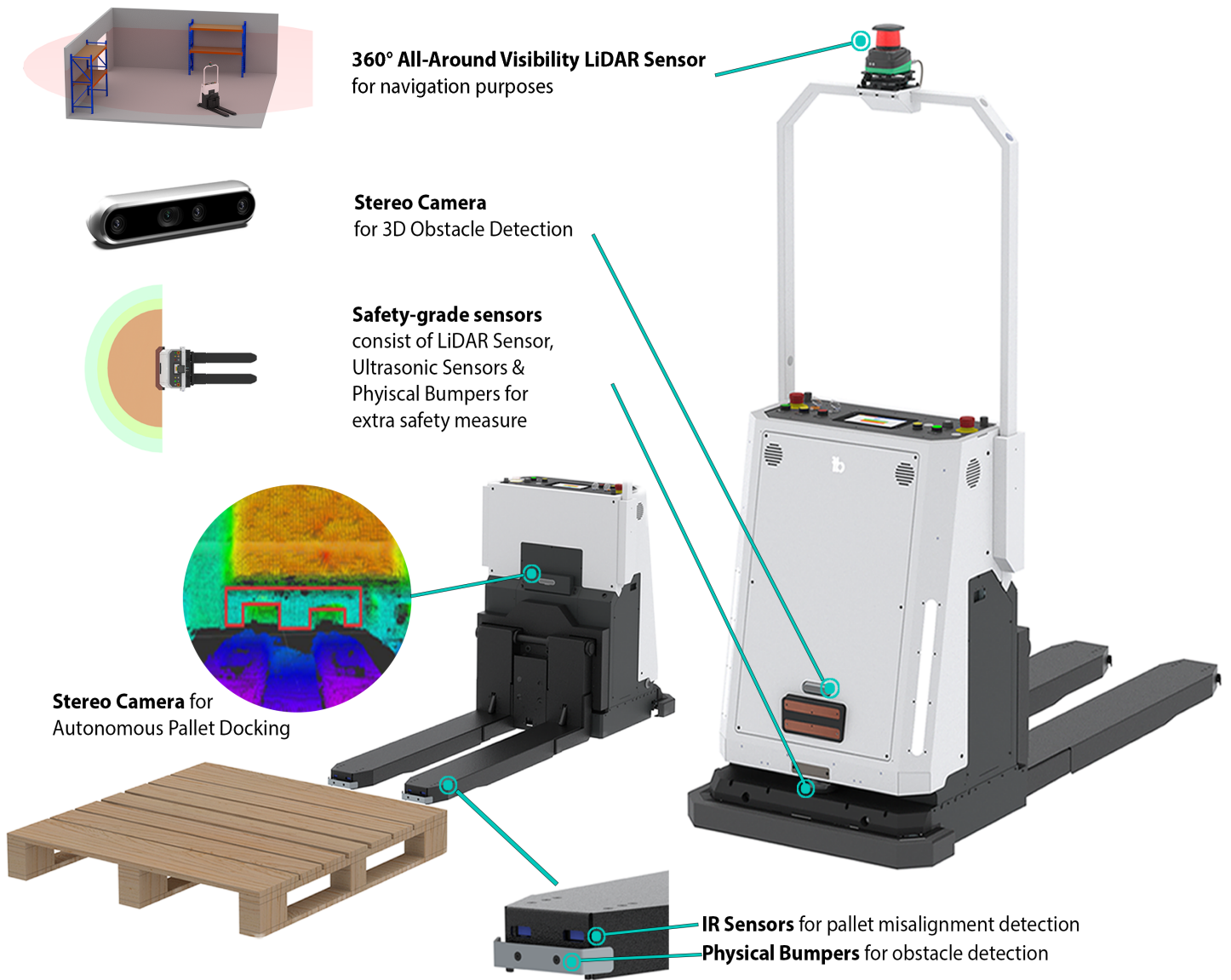

# Pallet Sizing

Dimensions	Minimum (mm)	Maximum (mm)
A	205	-
B	80	150
C	80	150
D	100	-
E	-	1200

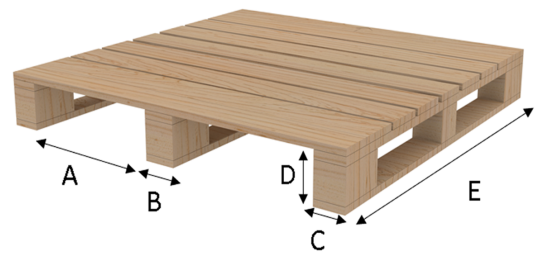

\*Only Support Open Pallet type

# Specification

## General

<b>Product Model</b>	Zetha - TS - S - 10
<b>Base Dimension</b>	L: 1960mm x W: 780mm x H: 2015mm - 2165mm
<b>Fork Dimension</b>	L: 1220mm x W: 200mm x H: 95mm

## Performance

<b>Payload</b>	1000kg
<b>Lifting Height</b>	100mm
<b>Maximum Speed</b>	1 m/s (3.6km/h)
<b>Stopping Accuracy</b>	Natural Feature: $\pm 50\text{mm} \pm 2^\circ$ Marker/Docking: $\pm 10\text{mm} \pm 1^\circ$
<b>Maximum Gradeability</b>	3% (1.72°)
<b>Drive Method</b>	2-Wheel Differential Drive
<b>Travelling Direction</b>	Forward, Reverse, 90°/180° turn
<b>Minimum Width for Pivoting</b>	2660mm
<b>System</b>	Standalone (NavWiz) / Fleet Management System (DFleet)

## Power

<b>Running Time (90% to 10%)</b>	12 hours
<b>Charging Time (10% to 90%)</b>	3 hours
<b>Charging Method</b>	Automatic & Manual Charging available
<b>Battery</b>	LiFePo4 Battery, 25.6V, 130Ah

## Feature and Interface

<b>Safety Feature</b>	Safety Grade Laser Scanner Front and Rear Bumper Switch Emergency Switch x2 External Safety Input/Output 3D Stereo Camera
<b>Safety Indicators</b>	Color LED lighting Music Playback & Alarm
<b>Onboard Interface</b>	7 inch Capacitive Touchscreen Physical Button
<b>WiFi Frequency</b>	802.11 ac/a/b/g/n, 2.4GHz / 5GHz Dual-Band WiFi
<b>Application Programming Interface (API)</b>	REST, Modbus, Webhooks

## DF AUTOMATION & ROBOTICS SDN BHD (1006594-V)

5, Jalan Impian Emas 18,  
Taman Impian Emas,  
81300 Skudai, Johor, Malaysia

+607-283 0001

+607-554 4269

sales@dfautomation.com

[www.dfautomation.com](http://www.dfautomation.com)

[f](#) dfautomation

[v](#) dfautomation